

# SECTION 5 - ELECTRICAL SYSTEM

---

---

## TABLE OF CONTENTS

---

---

Specifications .....	5-2
Battery .....	5-2
Testing Electrical Components .....	5-3
Brakelight Switch (Front Brake) .....	5-3
Brakelight Switch (Rear Brake) .....	5-3
Coolant Temperature and Cooling Fan Switches ....	5-4
Fan Motor .....	5-4
Fuse Holder .....	5-4
Fuse .....	5-5
Ignition Coil .....	5-5
Indicator Lights .....	5-6
Ignition Switch .....	5-7
Handlebar Control Switches .....	5-7
Neutral Switch .....	5-8
Clutch Lever Position Switch .....	5-9
Magneto Coils .....	5-9
Starter Motor .....	5-10
Starter Relay .....	5-13
CDI Unit .....	5-13
Regulator/Rectifier .....	5-13
Headlights .....	5-13
Taillight - Brakelight .....	5-14
Ignition Timing .....	5-14
Wiring Diagram .....	5-15

## Specifications

IGNITION	
Ignition Timing	10° BTDC @ 1500 RPM
Spark Plug Type	NGK CR7E
Spark Plug Gap	0.7-0.8 mm (0.028-0.032 in.)
Spark Plug Cap	12,000-20,000 ohms
Ignition Coil Resistance (primary)	1.0 ohm (terminal to ground)
(secondary)	130-200 ohms (high tension - plug cap removed - to ground)
Ignition Coil Peak Voltage (primary/CDI)	130+ volts (red test lead to black/white) (black test lead to black)
MAGNETO	
Magneto Coil Resistance (trigger)	350-670 ohms (green to blue)
(source)	0.09-0.50 ohm (black to white)
(charging)	0.1-1.5 ohms (brown to brown)
Magneto Coil Peak Voltage	
(trigger)	2.0+ volts (green to blue)
(source)	0.10+ volt (black to white)
(charging)	14-15.5 D.C. volts (black test lead to (-) battery) (red test lead to (+) battery)
Magneto Output (approx)	220W @ 5000 RPM

## Battery

The battery is located under the seat.

The battery in this ATV is a “sealed” type and does not require any maintenance unless discharged. Distilled water and/or electrolyte cannot be added to the battery.

### ⚠ WARNING

Anytime service is performed on a battery, the following must be observed: keep sparks, open flame, cigarettes, or any other flame away. Always wear safety glasses. Protect skin and clothing when handling a battery. When servicing battery in enclosed space, keep the area well-ventilated.

This maintenance-free battery requires periodic charging to prevent sulfiding. If the ATV will be idle for extended periods of time, either run the engine or trickle charge from time to time. If the battery completely discharges, permanent damage will occur requiring replacement.

If the battery is discharged, remove the battery from the ATV and charge the battery at the standard charging rate of 0.9 amps for 5-10 hours.

To remove and charge the battery, use the following procedure.

1. Remove the seat assembly; then remove the battery hold-down bracket.
2. Remove the negative battery cable; then remove the positive cable. Remove the battery from the ATV.

### ⚠ WARNING

**Battery posts, terminals, and related accessories contain lead and lead compounds, chemicals known to the state of California to cause cancer and reproductive harm. Wash hands after handling.**

### ⚠ CAUTION

**Do not charge the battery while it is in the ATV with the battery terminals connected.**

3. Trickle charge the battery at 0.9 amps for 5-10 hours.

### ⚠ CAUTION

**Never exceed the standard charging rate.**

### ⚠ CAUTION

**Before installing the battery, make sure the ignition switch is in the OFF position.**

4. Place the battery into position in the ATV and secure with the hold-down bracket.
5. Clean the battery posts and cable ends by using a battery post cleaning tool and/or a wire brush to remove dirt, grease, and corrosion.
6. Connect cable to the proper terminals: positive cable to the positive terminal (+) and negative cable to the negative terminal (-). Connect the negative cable last.

### ⚠ CAUTION

**Connecting cables in reverse (positive to negative and negative to positive) can cause serious damage to the electrical system.**

---

---

## Testing Electrical Components

---

All of the electrical tests should be made using the Fluke Model 73 Multimeter (p/n 0644-191) and when testing peak voltage, the Peak Voltage Reading Adapter (p/n 0644-307) must be used. If any other type of meter is used, readings may vary due to internal circuitry. When troubleshooting a specific component, always verify first that the fuse is good, that the bulbs are good, that the connections are clean and tight, that the battery is fully charged, and that all appropriate switches are activated.

■ **NOTE:** For absolute accuracy, all tests should be made at room temperature of 68° F.

---

---

## Brakelight Switch (Front Brake)

---

■ **NOTE:** For ease of access to the electrical connectors, removing the seat and body is recommended (see Section 8).

The switch connector is the two-prong one located in front of the steering post.

### RESISTANCE (Switch Connector)

 **CAUTION**

Always disconnect the battery when performing resistance tests to avoid damaging the multimeter.

1. Set the meter selector to the OHMS position.
2. Connect the red tester lead to the orange wire; then connect the black tester lead to the black/white wire.
3. When the brake lever is compressed, the meter must show less than 1 ohm.

■ **NOTE:** If the meter shows more than 1 ohm of resistance, troubleshoot or replace the switch/component, the connector, or the switch wiring harness.

---

---

## Brakelight Switch (Rear Brake)

---

The switch connector is the two-prong connector located along the upper right frame rail.

### RESISTANCE (Switch Connector)

 **CAUTION**

Always disconnect the battery when performing resistance tests to avoid damaging the multimeter.

■ **NOTE:** The brake pedal must be depressed for this test. Also, the ignition switch must be in the OFF position.

1. Set the meter selector to the OHMS position.
2. Connect the red tester lead to the orange wire; then connect the black tester lead to the black/white wire.

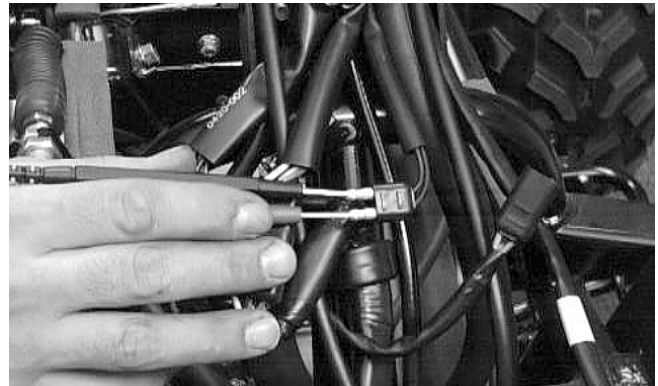

AR621D

3. When the pedal is depressed, the meter must show less than 1 ohm.

■ **NOTE:** If the meter shows more than 1 ohm of resistance, troubleshoot or replace the switch/component, the connector, or the switch wiring harness.

---

---

## Coolant Temperature and Cooling Fan Switches

---

1. Connect the meter leads (selector in the OHMS position) to the switch contacts.
2. Suspend the switch and a thermometer in a container of water; then heat the water.

■ **NOTE:** Neither the switch nor the thermometer should be allowed to touch the bottom of the container or inaccurate readings will occur. Use wire holders to suspend switch and thermometer.

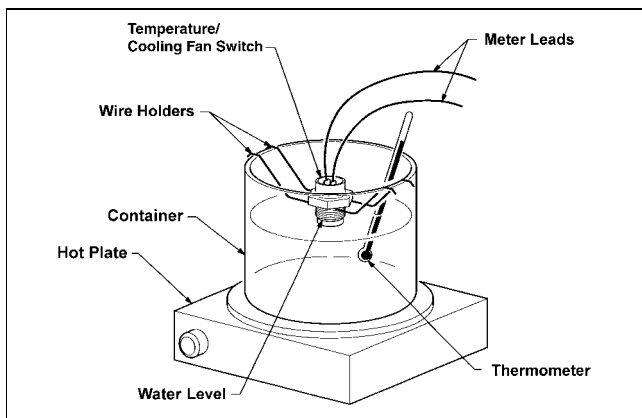

733-554E

3. On the coolant temperature switch when the water temperature reaches 120° C (248° F), the meter should read a closed circuit.
4. On the coolant temperature switch, allow the water to cool, and when the temperature is at (or just before) a temperature of 113° C (235° F), the meter should read an open circuit.
5. On the cooling fan switch when the temperature reaches 88° C (190° F), the meter should read a closed circuit.
6. On the cooling fan switch, allow the water to cool, and when the temperature is at (or just before) a temperature of 82° C (180° F), the meter should read an open circuit.
7. If the readings are not as indicated, the switch must be replaced.
8. Install the switch and tighten securely.
9. Connect the switch leads.

---

---

## Fan Motor

---

■ **NOTE:** The ignition switch must be in the ON position.

### VOLTAGE (Main Harness Connector to Fan Motor)

1. Set the meter selector to the D.C. Voltage position.
2. Connect the red tester lead to the orange wire (the black 2-prong at the fan motor); then connect the black tester lead to ground.
3. The meter must show battery voltage.

■ **NOTE:** If the meter shows no battery voltage, troubleshoot the battery, fuse, motor, or the main wiring harness.

■ **NOTE:** If the meter shows battery voltage, the main wiring harness is good. The connector should be tested for resistance.

■ **NOTE:** To determine if the fan motor is good, connect the red wire from the fan connector to a 12 volt D.C. power supply; then connect the black/red wire from the fan connector to ground. The fan should operate.

### ⚠ CAUTION

Care should be taken to keep clear of the fan blades.

---

---

## Fuse Holder

---

The fuse and a spare are located on the starter relay under the seat.

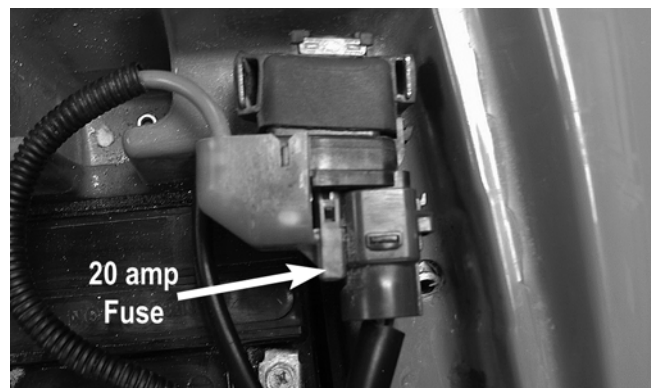

SP032A

1. Remove the fuse from the starter relay.

2. Set the meter selector to the D.C. Voltage position.
3. Connect the black tester lead to ground.
4. Using the red tester lead, contact the battery side of the fuse holder connector terminal.
5. The meter must show battery voltage.

■ **NOTE:** Battery voltage will be indicated from only one side of the fuse holder connector terminal; the other side will show an open circuit.

■ **NOTE:** If the meter shows no battery voltage, troubleshoot the battery, switches, fuse holder, or the main wiring harness.

## Fuse

### ⚠ CAUTION

**Always disconnect the battery when performing resistance tests to avoid damaging the multimeter.**

1. Set the meter selector to the OHMS position.
2. Connect the red tester lead to one spade end of the fuse; then connect the black tester lead to the other spade end.

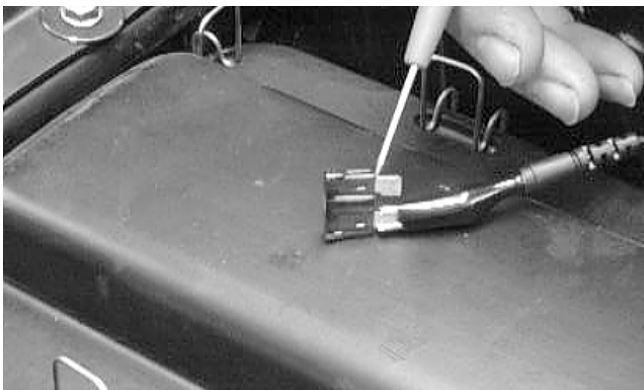

AR610D

3. The meter must show less than 1 ohm resistance. If the meter reads open, replace the fuse.

## Ignition Coil

The ignition coil is attached to the upper frame near the top of the radiator. To access the coil, the seat, body, and gas tank must be removed (see Section 8).

### PEAK VOLTAGE (Primary Side)

■ **NOTE:** Peak voltage test should be made using the Fluke Model 73 Multimeter (p/n 0644-191) with Peak Voltage Reading Adapter (p/n 0644-307). If any other type of tester is used, reading may vary due to internal circuitry.

■ **NOTE:** The battery must be at full charge for this test.

■ **NOTE:** The ignition switch must be in the ON position; the emergency stop switch must be in the RUN position.

1. Remove the spark plug cap; then connect a new spark plug to the spark plug cap and ground it to the cylinder head.
2. Using the multimeter with the peak voltage adapter, connect the red tester lead (+) to the black/white lead wire (or to ground) and the black tester lead (-) to the black wire.



SP313

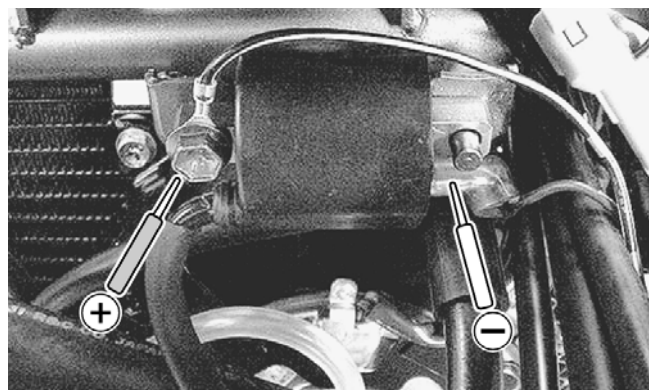

SP314

3. Set the meter selector to the D.C. Voltage position.

4. With the tester leads connected, compress the clutch lever and depress the starter button.

5. The meter reading must be within specification.

■ **NOTE:** If the voltage is not as specified, inspect the main wiring harness, connectors, source/charge coil, magneto rotor and magnets, magneto rotor key, or the CDI unit.

## RESISTANCE

### ⚠ CAUTION

Always disconnect the battery when performing resistance tests to avoid damaging the multimeter.

■ **NOTE:** For these tests, the meter selector should be set to the OHMS position.

### Primary Winding

1. Connect the red tester lead to the terminal (with the wire removed); then connect the black tester lead to ground.

2. The meter reading must be within specification.

### Secondary Winding

1. Connect the red tester lead to the high tension lead (plug cap removed); then connect the black tester lead to ground.

2. The meter reading must be within specification.

■ **NOTE:** If the meter does not show as specified, replace ignition coil.

### Spark Plug Cap

1. Connect the red tester lead to one end of the cap; then connect the black tester lead to the other end of the cap.

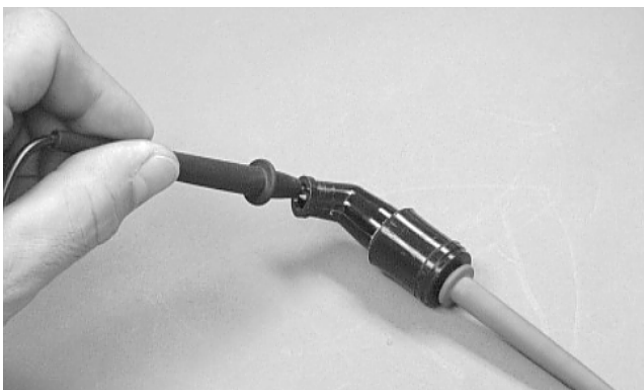

AR603D

2. The meter reading must be within specification.

■ **NOTE:** If the meter does not show as specified, replace the spark plug cap.

## Indicator Lights

The indicator lights connector being tested is the four-wire one in front of the steering post.

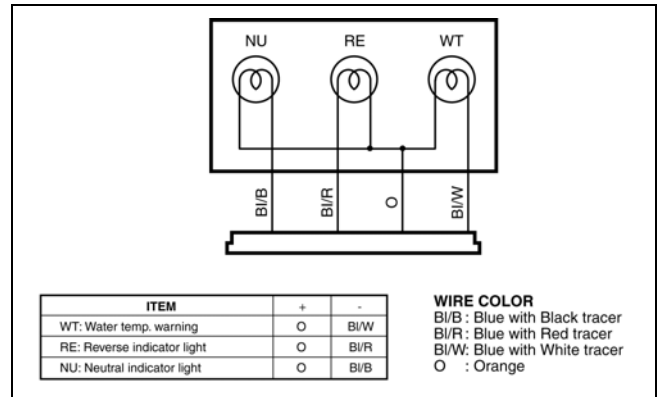

ATV2183

To access the indicator light connector for testing purposes, use the following procedure.

1. Remove the seat and body (see Section 8).
2. Disconnect the four-wire connector from the main wiring harness.

■ **NOTE:** For these tests, a 12-volt power supply “jumper” should be used to supply power.

### WATER TEMPERATURE INDICATOR LIGHT

1. Connect the jumper positive wire to the power source terminal on the indicator light connector.
2. Connect the jumper ground wire to the blue/white (temperature) wire on the indicator light connector.
3. The water temperature indicator light should illuminate.

### NEUTRAL INDICATOR LIGHT

1. Connect the jumper positive wire to the power source terminal on the indicator light connector.
2. Connect the jumper ground wire to the blue/black (neutral) wire on the indicator light connector.
3. The neutral indicator light should illuminate.

### REVERSE INDICATOR LIGHT

1. Connect the jumper positive wire to the power source terminal on the indicator light connector.
2. Connect the jumper ground wire to the blue/red (reverse) wire on the indicator light connector.
3. The reverse indicator light should illuminate.

■ **NOTE:** If a light fails to illuminate in any one of the indicator light tests, the connector, wiring harness, or a bulb must be replaced.

### INDICATOR LIGHTS VOLTAGE

■ **NOTE:** The ignition switch must be in the ON position, and the test must be performed on the lower side of the connector.

1. Set the meter selector to the D.C. Voltage position.
2. Connect the red tester lead to the orange wire; then connect the black tester lead to ground.
3. The meter must show battery voltage.

■ **NOTE:** This is the only voltage test for all indicator lights.

After testing procedures are completed, use the following procedure.

1. Connect the indicator light four-wire connector to the main harness.
2. Install the body and seat (see Section 8).

---

---

## Ignition Switch

---

The connector is the three-wire one in front of the steering post. To access the connector, the body and seat must be removed (see Section 8).

### VOLTAGE

■ **NOTE:** Perform this test on the lower side of the connector.

1. Set the meter selector to the D.C. Voltage position.
2. Connect the red meter lead to the red wire; then connect the black meter lead to ground.
3. Meter must show battery voltage.

■ **NOTE:** If the meter shows no battery voltage, troubleshoot the battery or the main wiring harness.

### RESISTANCE

 **CAUTION**

Always disconnect the battery when performing resistance tests to avoid damaging the multimeter.

■ **NOTE:** Perform this test on the upper side of the connector.

1. Turn the ignition switch to the ON position.
2. Set the meter selector to the OHMS position.
3. Connect the red tester lead to the red wire; then connect the black tester lead to the orange wire.
4. The meter must show less than 1 ohm.
5. Turn the ignition switch to the LIGHTS position.
6. Connect the red tester lead to the red wire; then connect the black tester lead to the orange wire.
7. The meter must show less than 1 ohm.
8. Connect the red tester lead to the red wire; then connect the black tester lead to the gray wire.
9. The meter must show less than 1 ohm.
10. With the switch in the OFF position, connect the red tester lead to the red wire and the black tester lead to each of the remaining wires (orange and gray). The meter must show an open circuit on both wires.

■ **NOTE:** If the meter shows more than 1 ohm of resistance, troubleshoot or replace the switch/component, the connector, or the switch wiring harness.

---

---

## Handlebar Control Switches

---

The connector is the yellow one in front of the steering post. To access the connector, the body and seat must be removed (see Section 8).

■ **NOTE:** These tests should be made on the top side of the connector.

 **CAUTION**

Always disconnect the battery when performing resistance tests to avoid damaging the multimeter.

### RESISTANCE (HI Beam)

1. Set the meter selector to the OHMS position.
2. Connect the red tester lead to the yellow wire; then connect the black tester lead to the gray wire.
3. With the dimmer switch in the HI position, the meter must show less than 1 ohm.

■ **NOTE:** If the meter shows more than 1 ohm of resistance, troubleshoot or replace the switch/component, the connector, or the switch wiring harness.

## RESISTANCE (LO Beam)

1. Set the meter selector to the OHMS position.
2. Connect the red tester lead to the white wire; then connect the black tester lead to the gray wire.
3. With the dimmer switch in the LO position, the meter must show an open circuit.

■ **NOTE:** If the meter reads resistance, troubleshoot or replace the switch/component, the connector, or the switch wiring harness.

## RESISTANCE (Starter Button)

1. Set the meter selector to the OHMS position.
2. Connect the red tester lead to the orange/white wire; then connect the black tester lead to the black wire.
3. With the starter button depressed, the meter must show less than 1 ohm.
4. With the starter button released, the meter must show an open circuit.

■ **NOTE:** If the meter does not show as specified, replace the switch/component, connector, or switch harness.

## RESISTANCE (Emergency Stop)

1. Set the meter selector to the OHMS position.
2. Connect the red tester lead to the orange wire; then connect the black tester lead to the orange/white wire.
3. With the switch in the OFF position, the meter must show an open circuit.
4. With the switch in the RUN position, the meter must show less than 1 ohm.

■ **NOTE:** If the meter shows more than 1 ohm of resistance, troubleshoot or replace the switch/component, the connector, or the switch wiring harness.

---

---

# Neutral Switch

---

## RESISTANCE

### CAUTION

Always disconnect the battery when performing resistance tests to avoid damaging the multimeter.

1. Disconnect the battery; then disconnect the white four-wire connector located to the rear of the regulator/rectifier.



SP081A

2. Set the meter selector to the OHMS position; then connect the black meter lead to the black wire and the red meter lead to the blue wire.
3. With the transmission in neutral, the meter should show less than 1 ohm.
4. Depress the gear shifter pedal to engage first gear. The meter should show an open circuit.
5. Connect the red meter lead to the white wire. The meter should show less than 1 ohm.
6. Rotate the reverse selector knob clockwise and depress the gear shifter pedal to engage reverse gear; then connect the red meter lead to the red wire. The meter must show less than 1 ohm.
7. Lift the gear shifter pedal twice to return to neutral. The meter must show an open circuit.



---

---

## Clutch Lever Position Switch

---

### RESISTANCE

**⚠ CAUTION**

Always disconnect the battery when performing resistance tests to avoid damaging the multimeter.

1. Disconnect the battery; then disconnect the two-wire connector at the steering post.
2. Set the meter selector to the OHMS position; then connect the black meter lead to the black wire and the red meter lead to the yellow/black wire.
3. Compress the clutch lever. The meter should show less than 1 ohm. Release the clutch lever and verify that the meter shows an open circuit.

---

---

## Magneto Coils

---

■ **NOTE:** All peak voltage tests should be made using the Fluke Model 73 Multimeter (p/n 0644-191) with Peak Voltage Reading Adapter (p/n 0644-307). If any other type of tester is used, readings may vary due to internal circuitry.

■ **NOTE:** The battery must be at full charge for this test.

### PEAK VOLTAGE (Charging Coil - Output)

1. Set the meter selector to the D.C. Voltage position.
2. Connect the red tester lead to the positive battery post; then connect the black tester lead to the negative battery post.
3. With the engine running at a constant 5000 RPM (with the headlights on), the meter must be within specification.

**⚠ CAUTION**

Do not run the engine at high RPM for more than 10 seconds.

■ **NOTE:** If voltage is lower than specified, test Charging Coil - No Load.

### VOLTAGE (Charging Coil - No Load)

■ **NOTE:** The peak voltage reading adapter must be disconnected for this test.

The connector is the black one on the left side near the voltage regulator.

■ **NOTE:** Test the connector that comes from the engine.



SP084A

1. Set the meter selector to the A.C. Voltage position.
2. Test between the three brown wires for a total of three tests.

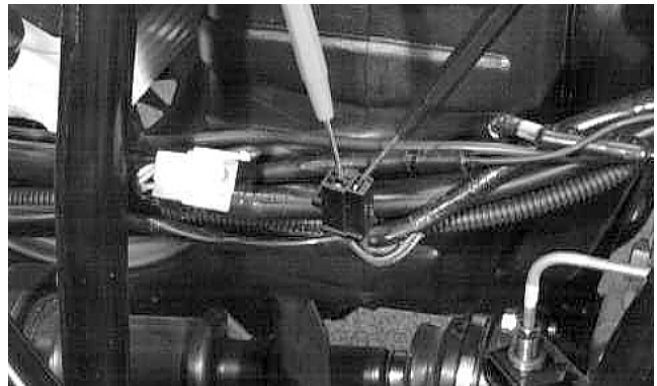

AR630D

3. With the engine running at a constant 5000 RPM, all wire tests must show 65+ A.C. volts.

**⚠ CAUTION**

Do not run the engine at high RPM for more than 10 seconds.

■ **NOTE:** If both charging coil tests failed, check all connections, etc., and test again. If no voltage is present, replace the stator assembly.

## RESISTANCE (Charging Coil)

### ⚠ CAUTION

Always disconnect the battery when performing resistance tests to avoid damaging the multimeter.

1. Set the meter selector to OHMS position.
2. Test between the three brown wires for a total of three tests.
3. The meter reading must be within specification.

## RESISTANCE (Trigger Coil)

### ⚠ CAUTION

Always disconnect the battery when performing resistance tests to avoid damaging the multimeter.

1. Set the meter selector to the OHMS position.
2. Connect the red tester lead to the green wire; then connect the black tester lead to the blue wire. The meter reading must be within specification.

## RESISTANCE (Source Coil)

### ⚠ CAUTION

Always disconnect the battery when performing resistance tests to avoid damaging the multimeter.

1. Set the meter selector to the OHMS position.
2. Connect the red tester lead to the black wire; then connect the black tester lead to the white wire.
3. The meter reading must be within specification.

■ **NOTE:** If the meter shows other than specified in any resistance test, replace the stator assembly.

## PEAK VOLTAGE (Magneto Coil - Trigger)

1. Set the meter selector to the D.C. Voltage position.
2. Connect the red tester lead to the green wire; then connect the black tester lead to the blue wire.
3. Crank the engine over using the electric starter.
4. The meter reading must be within specification.

## PEAK VOLTAGE (Magneto Coil - Source)

1. Set the meter selector to the D.C. Voltage position.
2. Connect the red tester lead to the black wire; then connect the black tester lead to the white wire.
3. Crank the engine over using the electric starter.

4. The meter reading must be within specification.

# Starter Motor

## REMOVING/DISASSEMBLING

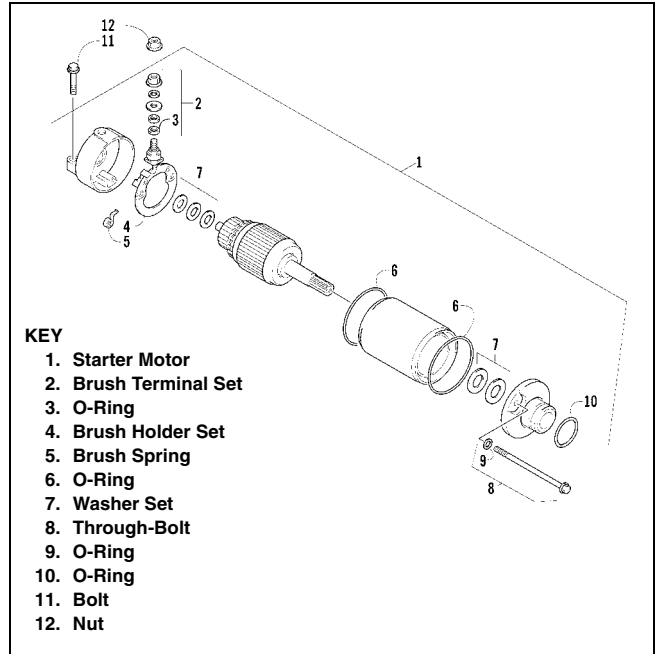

0739-228

1. Disconnect the battery.

### ⚠ CAUTION

Always disconnect the negative battery cable from the battery first; then disconnect the positive cable.

2. Remove the nut securing the positive cable to the starter; then remove the cable from the starter.
3. Remove the cap screws securing the starter to the crankcase; then remove the starter.
4. For assembly purposes, scribe a line across the outside of the starter assembly.



AR652D

5. Remove the two through-bolts securing the starter components. Account for the O-rings.
6. Remove the left-side cover from the starter housing. Account for washers and housing O-ring.
7. Remove the right-side cover. Account for washers and housing O-ring.
8. Slide the armature free of the starter housing.
9. Remove the nut from the positive post. Account for the lock washer, flat washer, a fiber washer, and an O-ring.
10. Bend the two positive brushes outward; then remove the brush holder. Account for two brush springs and brushes.

## CLEANING AND INSPECTING

■ **NOTE:** Whenever a part is worn excessively, cracked, or damaged in any way, replacement is necessary.

1. Thoroughly clean all components except the armature and brushes in parts-cleaning solvent; then dry with compressed air.

### CAUTION

**Do not wash the armature and brushes in any kind of solvent. Use only compressed air and a clean dry, lint-free cloth.**

2. Inspect all threaded areas for damage or stripped threads.
3. Inspect the brush holder assembly and brushes for damage or wear. Using a caliper, measure the length of the brushes. If brush measurement is less than 10.1 mm (0.40 in.), replace with new brushes and brush springs as a set.
4. Inspect the brush leads for cracks, wear, or fraying. If any of these conditions exist, replace with new brushes and brush springs as a set.
5. Inspect the left-side cover bushing for wear.
6. Inspect the right-side cover bushing for wear.
7. Inspect the brass commutator end of the armature for any burned spots or damage. If the commutator is lightly burned or damaged, the armature must be replaced. This is a molded commutator and turning it down in a lathe should not be attempted.

### CAUTION

**Do not use emery cloth to clean the commutator as emery particles will become imbedded in the brass commutator resulting in a short circuit. Use only #200 grit sandpaper.**

8. Inspect the commutator end of the armature for buildup in the grooves. Carefully remove any buildup by undercutting using a thinly ground hacksaw blade. Do not undercut any deeper than the original groove which can be seen by looking at the end of the commutator.
9. Using a caliper, measure the undercut. Maximum undercut groove must be 0.2 mm (0.008 in.).

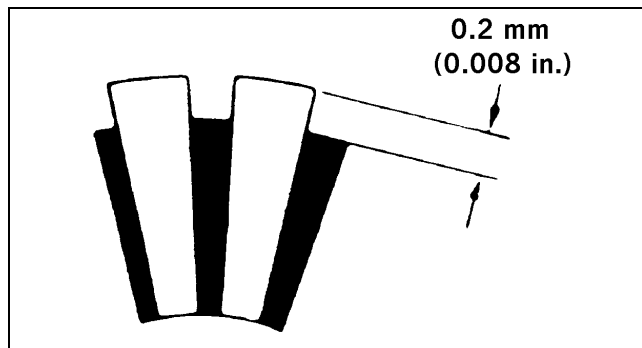

ATV-1054

### CAUTION

**Buildup in the grooves must be removed to prevent any chance of an electrical arc between individual sections of the commutator.**

10. Inspect the commutator for shorting using a multimeter and the following procedure.
  - A. Set the selector to the OHMS position.
  - B. Touch the black lead to the armature shaft.
  - C. Using the red tester lead, probe the commutator end of the armature. The meter indicator should not change. If the indicator shows resistance, the armature is shorted and must be replaced.
11. Inspect the armature for shorting using a “growler” and the following procedure.
  - A. Place the armature in the “growler.”
  - B. While holding a metal strip on the armature, rotate the armature an entire revolution. If the metal strip vibrates at any point on the armature, the armature is shorted and must be replaced.

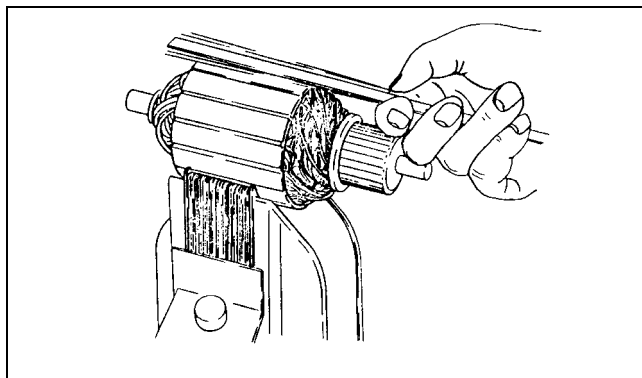

0725-653

12. Inspect the ground brushes to make sure they are properly grounded. Use a multimeter and the following procedure.
  - A. Set the selector to the OHMS position.
  - B. Touch the black tester lead to a ground brush.
  - C. Touch the red tester lead to the brush holder assembly.

■ **NOTE: If no resistance is indicated, check the ground connection for tightness and for cleanliness. If there is still no meter indication, replace the brush assembly.**

## ASSEMBLING/INSTALLING

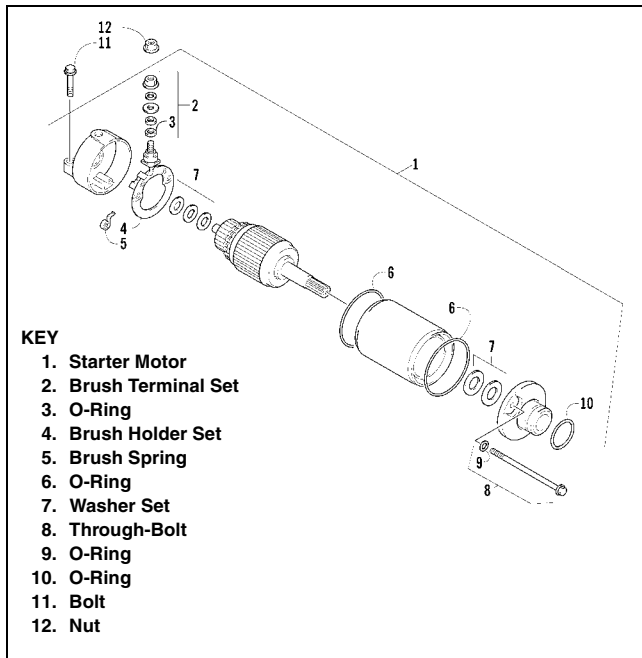

0739-228

1. Align the tab on the brush holder with the notch in the right-side cover; then install the holder.
2. On the positive post, install an O-ring washer, a fiber washer, a flat washer, and a lock washer. Secure with the nut.
3. Install the armature into the starter housing; then while holding the brushes out, slide the commutator into the brush holder.
4. Apply a small amount of grease to the right-side cover bushing; then install the cover on the starter housing making sure the O-ring is in place and the reference marks align.
5. Install the washer set on the armature shaft; then install the housing O-ring on the starter housing.
6. Apply a small amount of grease to the left-side cover bushing.

7. Place the left-side cover onto the starter housing making sure the housing O-ring is in place and it seats properly.
8. Apply red Loctite #271 to the threads of the two through-bolts and install. Tighten to specification.
9. Apply a small amount of grease to the O-ring seal on the starter; then install the starter into the crankcase. Secure with cap screws and wiring forms. Tighten cap screws securely.
10. Secure the positive cable to the starter with the nut and tighten to specification.
11. Connect the battery making sure to connect the positive cable first.

## TESTING VOLTAGE

Perform this test on the starter motor positive terminal.

■ **NOTE: The ignition switch must be in the ON position, the emergency stop switch in the RUN position, the reverse lever (on manual transmission models) in the FORWARD position, and the shift lever (on automatic transmission models) in the NEUTRAL position.**

1. Set the meter selector to the D.C. Voltage position.
2. Connect the red tester lead to the starter terminal; then connect the black tester lead to ground.
3. With the starter button depressed, the meter must show battery voltage and the starter motor should operate.



AR607D

■ **NOTE: If the meter showed battery voltage but the starter did not operate or operated slowly, inspect battery voltage (at the battery), starter motor condition, and/or ground connections.**

■ **NOTE: If the meter showed no battery voltage, inspect the main fuse, ground connections, starter motor lead, battery voltage (at the battery), or the switches.**

---

---

## Starter Relay

---

### VOLTAGE

1. Remove the seat.
2. Set the meter selector to D.C. Voltage position; then connect the red tester lead to the battery side of the starter relay and the black tester lead to the starter cable side of the starter relay.
3. The meter must show battery voltage.

■ **NOTE:** If the meter showed no battery voltage, check the battery for charge or battery to solenoid connections.

4. Turn the ignition switch to the ON position, compress the clutch lever, and depress the starter button.
5. The meter must show 0 D.C. volts and the starter motor should run.

■ **NOTE:** If the meter shows voltage, replace the starter relay. If the meter shows battery voltage, continue with step 6.

6. Connect the red tester lead to the yellow/black wire on the starter relay; then connect the black tester lead to ground.
7. Compress the clutch lever; then depress the starter button.
8. The meter should show battery voltage.

■ **NOTE:** If the meter shows battery voltage, the starter relay is defective. If the meter does not show battery voltage, troubleshoot the starter switch, emergency stop switch, clutch lever position, or the ignition switch.

---

---

## CDI Unit

---

The CDI is located beneath the left rear fender near the voltage regulator.

■ **NOTE:** The CDI unit is not a serviceable component. If the unit is defective, it must be replaced.

The CDI is rarely the cause for electrical problems; however, if the CDI is suspected, substitute another CDI unit to verify the suspected one is defective.

■ **NOTE:** Prior to replacing the CDI unit to assure the CDI unit is defective, it is advisable to perform a CDI peak voltage test (see Ignition Coil in this section) and/or perform a continuity test of the wiring harness from the CDI connector to the CDI unit.

[Back to Table of Contents](#)

---

---

## Regulator/Rectifier

---

The regulator/rectifier is located under the left rear fender on the upper frame rail.

■ **NOTE:** Before replacing the regulator/rectifier, perform the following checks.

1. Clean and tighten all battery connections; then clean and inspect the three-wire connector from the magneto charging coil.



SP084A

2. Perform the Peak Voltage (Charging Coil - Output) check under the Magneto Coils sub-section.

■ **NOTE:** If the voltage is too high, recheck the battery connections, battery condition, or replace the regulator/rectifier.

3. Perform the Voltage (Charging Coil - No Load) check under Magneto Coils sub-section.

■ **NOTE:** If the charge coil test is within specifications, replace the regulator/rectifier.

---

---

## Headlights

---

The headlight are halogen bulbs with two-wire plug connectors. The headlight housing contains two high beam and one low beam bulb assemblies.

### **WARNING**

**Do not touch halogen bulbs while power is applied as severe burns may result.**

■ **NOTE:** The center bulb is the low beam one.

1. Turn the ignition switch to the lights position; then note which bulb/bulbs do not illuminate. Be sure to check both high beam and low beam positions.

[Back to Section TOC](#)

2. Disconnect the two-wire plug connector from the appropriate bulb; then select the D.C. Voltage position on the multimeter.
3. Connect the black tester lead to the black wire; then connect the red tester lead to the white wire (high beam) or the yellow wire (low beam).
4. The meter should show 12 D.C. volts.

■ **NOTE:** If the meter shows 12 D.C. volts, replace the bulb. If the meter shows 0 volts, check the headlight harness adapter.

---



---

## Taillight - Brakelight

---

The connector is the 3-prong one located under the rear body assembly.

### BULB VERIFICATION

■ **NOTE:** Perform this test on the taillight-brakelight side of the connector. Also, a 12-volt external power supply (jumper) will be needed.

1. Connect the power supply (positive) to the yellow wire; then connect the power supply (negative) to the brown wire.
2. The taillight should illuminate.
3. With the negative power supply still connected, connect the positive supply wire to the red wire.
4. The brakelight should illuminate.

■ **NOTE:** If either the taillight or brakelight fails to illuminate, inspect the bulb, the connectors, or the component wiring harness.

### VOLTAGE (Taillight)

■ **NOTE:** Perform this test on the harness side of the connector. Also, the ignition switch should be in the LIGHTS position.

1. Set the meter selector to the D.C. Voltage position.
2. Connect the red tester lead to the gray wire; then connect the black tester lead to the white/black wire.
3. With the ignition key in the LIGHTS position, the meter must show battery voltage.

■ **NOTE:** If the meter shows no voltage, inspect fuses, wiring harness, connectors, and switches. If the meter shows battery voltage, replace the bulb.

### VOLTAGE (Brakelight)

■ **NOTE:** Perform this test on the main harness side of the connector. Also, the ignition switch should be in the ON position and the brake (either foot pedal or hand lever) must be applied.

■ **NOTE:** Make sure the brake lever (front) and brake pedal (rear) are properly adjusted for this procedure.

1. Set the meter selector to the D.C. Voltage position.
2. Connect the red tester lead to the black/white wire; then connect the black tester lead to the white/black wire.
3. With either brake applied, the meter must show battery voltage.

■ **NOTE:** If the meter shows no voltage, inspect bulb, fuses, wiring harness, connectors, and switches. If the meter shows battery voltage, replace the bulb.

---



---

## Ignition Timing

---

The ignition timing cannot be adjusted; however, verifying ignition timing can aid in troubleshooting other components. To verify engine timing, use the following procedure.

1. Attach the engine Timing Light (p/n 0644-197) to the spark plug high tension lead; then remove the timing inspection plug from the left-side magneto cover.
2. With the Arctic Cat Engine Tachometer (p/n 0644-275) connected, start the engine and run at the specified RPM.
3. Ignition timing should be according to specification.
4. Install the timing inspection plug.

If ignition timing cannot be verified, the rotor may be damaged, the key may be sheared, the trigger coil bracket may be bent or damaged, or the CDI unit may be faulty.

# Wiring Diagram Harness (p/n 3509-007)

- 1 LIGHTS, INDICATOR
- 2 SWITCH, DIMMER
- 3 SWITCH, STOP
- 4 SWITCH, STARTER
- 5 SWITCH, HAND CLUTCH
- 6 SWITCH, HAND BRAKE
- 7 SWITCH, FOOT BRAKE
- 8 COIL, IGNITION
- 9 CDI
- 10 BRAKELIGHT/TAILLIGHT
- 11 BATTERY, 12V
- 12 RELAY, STARTER
- 13 MOTOR, STARTER
- 14 ENGINE MAGNETO
- 15 REGULATOR/ RECTIFIER
- 16 SWITCH, NEUTRAL
- 17 SWITCH, KEY
- 18 SWITCH, TEMP. FAN
- 19 FAN, COOLING
- 20 LIGHT, TEMP. SWITCH
- 21 HEADLIGHT, LOW-BEAM
- 22 HEADLIGHT, HIGH-BEAM

- WIRE COLORS**
- B :BLACK
  - BL :BLUE
  - BR :BROWN
  - DG :DARK GREEN
  - DGR :DARK GRAY
  - GR :GRAY
  - O :ORANGE
  - R :RED
  - W :WHITE
  - Y :YELLOW
  - B/BL :BLACK WITH BLUE TRACER
  - B/BR :BLACK WITH BROWN TRACER
  - B/G :BLACK WITH GREEN TRACER
  - B/O :BLACK WITH ORANGE TRACER
  - B/R :BLACK WITH RED TRACER
  - B/W :BLACK WITH WHITE TRACER
  - B/Y :BLACK WITH YELLOW TRACER
  - BL/B :BLUE WITH BLACK TRACER
  - BL/W :BLUE WITH WHITE TRACER
  - W/B :WHITE WITH BLACK TRACER
  - Y/B :YELLOW WITH BLACK TRACER

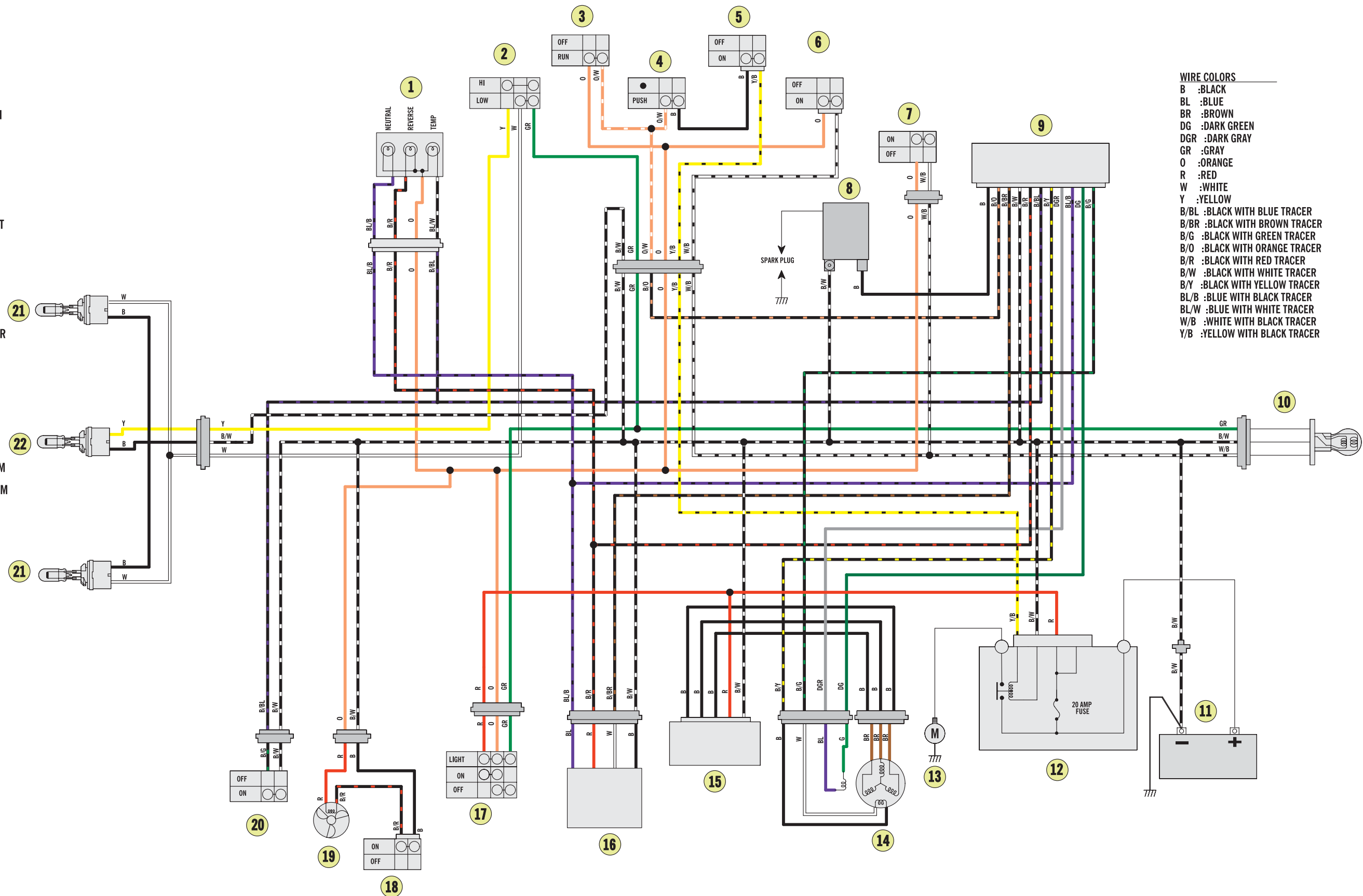

[Back to Table of Contents](#)

[Back to Section TOC](#)